

# Tegra<sup>®</sup>

## In-Air Digital Sorter

### Features & Benefits

- Gentle product Handling and acceleration
- Multiple camera configurations to match product requirements
- Vis/IR, UV or Tri-chromatic camera options
- Fluorescent, UV, & LED lighting options
- Simple, user-friendly operation, cleaning and maintenance
- Integrated and automated clean-in-place (CIP)
- Easy adjustment for product change over
- Information analytics for integration with process controls
- Wet or dry products

### Precise Removal of Defects and Foreign Material

Tegra's IntelliSort ejection system features 256 ejectors with a 6mm pitch to ensure complete removal of defects and foreign material with minimal collateral damage. Exceptional ejector response time with pinpoint accuracy for unparalleled performance increases yield.

### Precise Defect Identification

High resolution Vis/IR, Tri-chromatic, or UV cameras ensure even the subtlest defects are identified and targeted for removal. Object based image processing with sub-millimeter spatial resolution helps you improve quality.

### Intelligent Sorting

Top and Bottom cameras view product from all sides to detect size, shape, or color flaws. Contour or centered ejection based on product, defects and foreign material.

### Gentle Product Handling

Tegra's C-Belt uses gravity and centrifugal force to move product into the inspection zone without damage at consistent speed and volumes. The C-Belt stabilizes the product into a single uniform layer with even spacing for optimum viewing resulting in improved quality and increased yield.



*Tegra Full-wide*

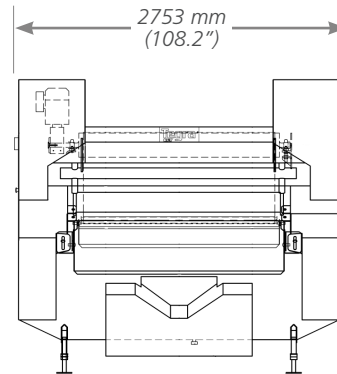
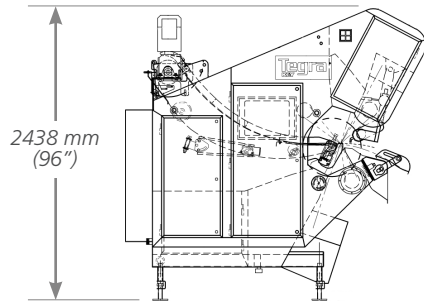
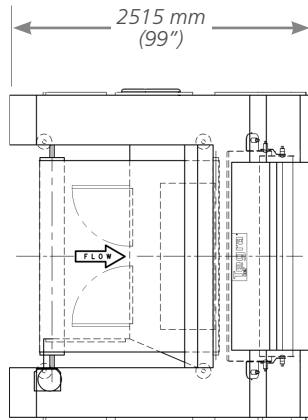

Tegra Full-wide

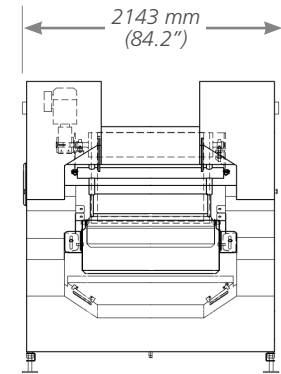
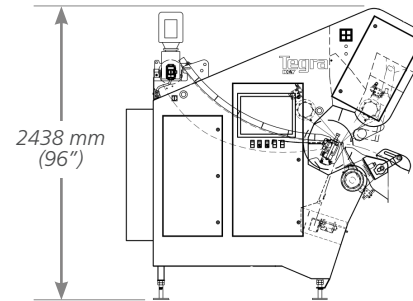
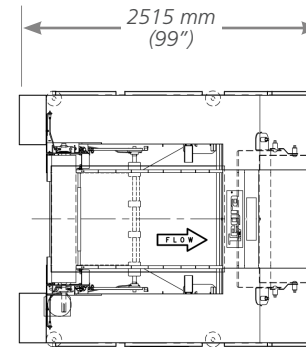

Tegra Half-wide

### Typical Applications

Vegetables (sliced and diced), fruit (whole, sliced, diced), potatoes (strips, sliced, diced, wedges), candy, coffee beans, nuts, snacks.

### Sorting Excellence

Color sorting sliced peaches on Tegra allowed a processor to pack glass jars by color for uniform appearance and high customer appeal.

### Result

Increased marketability of finished product

### Capacity

750mm up to 7.5 metric tons (16,500lbs)/hour\*

1500mm up to 15 metric tons(33,000lbs)/hour\*

\*Depending on product and defect load