

# Rotary Size Grader

The [Rotary Size Grader](#) removes short pieces, nubbins, loose seeds, and snipped ends of vegetables while conveying good product to downstream equipment.

The rotary bed consists of a series of pocket rollers, each with a stainless steel shaft and specific combinations of patented rubber rollers and plastic disks that create the pockets. As the pocket rollers rotate, target-size product settles in the pockets and passes through the bed to be discharged under the machine. Good product is conveyed to the end of the machine.

The Rotary Size Grader is ideal for small to medium-size product to be classified by length or volume. It is used for full line flow, regrading, and line flow directly from automatic defect removal systems such as Key Technology's [ADR](#)® line for french fries.



## Benefits

- Precise Sizing
  - “Stirring” action of the rotary bed moves target-size product into sizing pockets
  - Successful option to vibratory graders
  - Up to 95 percent removal of defects
  - Consistent sizing and absolute control
  - Customer selects target size parameters
- Easy Adjustment
  - Simple on-the-fly adjustment for rapid fine-tuning
  - Remove safety guard and bolts to exchange five pocket rollers for rollers targeting a different length
- Low Maintenance, Operation, and Installation Costs
  - Compact: efficient use of plant space
  - Transmits little vibration: simple, inexpensive installation
  - Low energy consumption
  - Easy access and simple maintenance

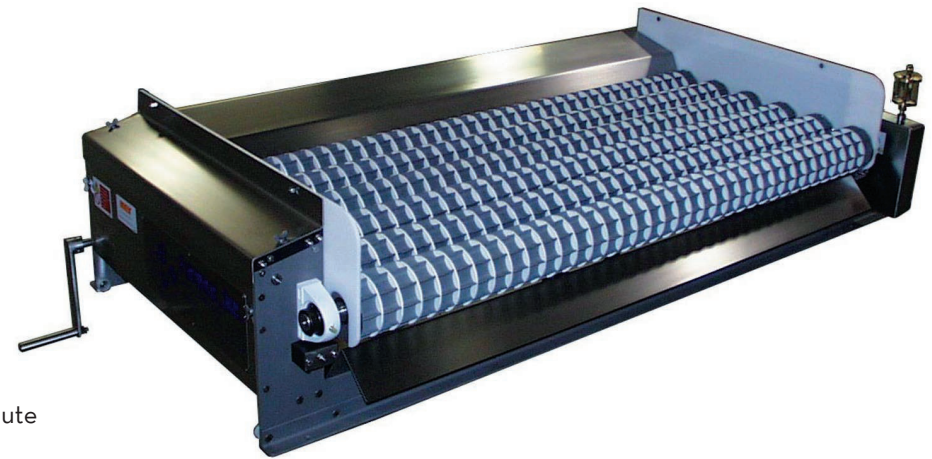

*RSG Sizing Pockets*

**Key Technology**

150 Avery Street • Walla Walla, WA 99362 • USA

Phone: 509.529.2161 • Fax: 509.527.1331 • [product.info@key.net](mailto:product.info@key.net) • [www.key.net](http://www.key.net)



## Specifications and Information

- Capacity: Varies with product and requirements
  - Current applications up to 6.80 metric tons per hour typical
- Dimensions:
  - Bed width: 1221 mm and 1524 mm (48" and 60")
  - Overall width: 2040 mm and 2345 mm (80-1/4" and 92-1/4")
  - Overall length: 926 mm (36-1/2")
- Efficiency: 95% or better
- Style: Platform model.
  - Legs, stands, chutes, hoppers, etc., not included
- Construction: Stainless steel, food grade
- Motor/Gearbox:
  - 0.75 kW (1 hp), 230/460V, 60Hz, 3-phase, gear motor standard
  - Other motor specifications available

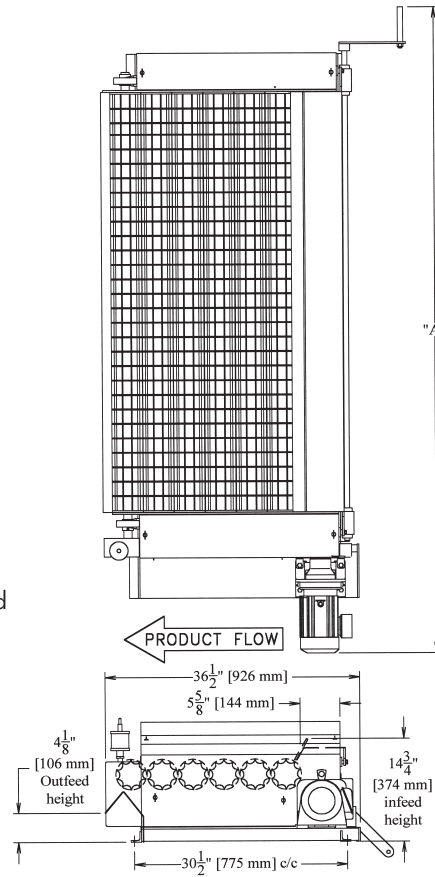

## Dimensions

Model		A	B	C
RSG	Inches	80 1/4	48	53 1/2
	(mm)	2040	1221	1359
RSG-5	Inches	92 1/4	60	65 1/2
	(mm)	2345	1524	1664

