

Distribution Systems

For projects large and small, Key's [Smart Shaker® vibratory conveyor](#) is the cost-effective, quality solution for distribution systems.

Modular design elements and over 50 years of engineering and process expertise harmonize to help meet your quality, cost, and schedule commitments. We can provide CAD-based systems layout, assistance during the proposal phase, and systems engineering and complete project management services during the project.

Complete Systems for Distribution to Weighing and Packaging Machines

- Modulated systems
- Recycling systems
- [Forté integrated control systems](#) available (UL approved)
- Can incorporate "S" option for conveying fragile products providing a sliding, linear motion and pan scrubbing
- Available with [mechanical \(Iso-Flo®\)](#) or [electromagnetic \(Impulse™\)](#) drives
- Feed product for process efficiency to washers, cutters, graders, Key optical sorters, cookers, fryers, dryers, scales



Key Technology

150 Avery Street • Walla Walla, WA 99362 • USA

Phone: 509.529.2161 • Fax: 509.527.1331 • product.info@key.net • www.key.net



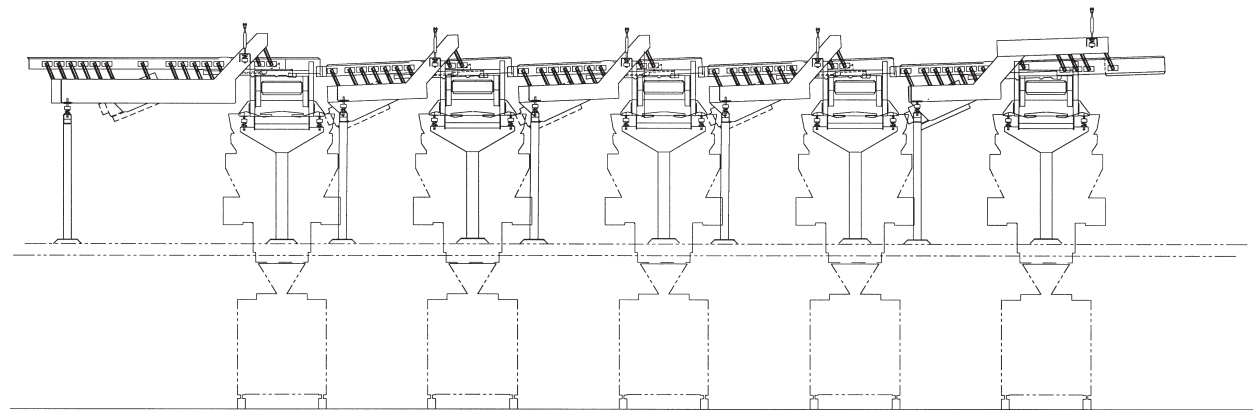
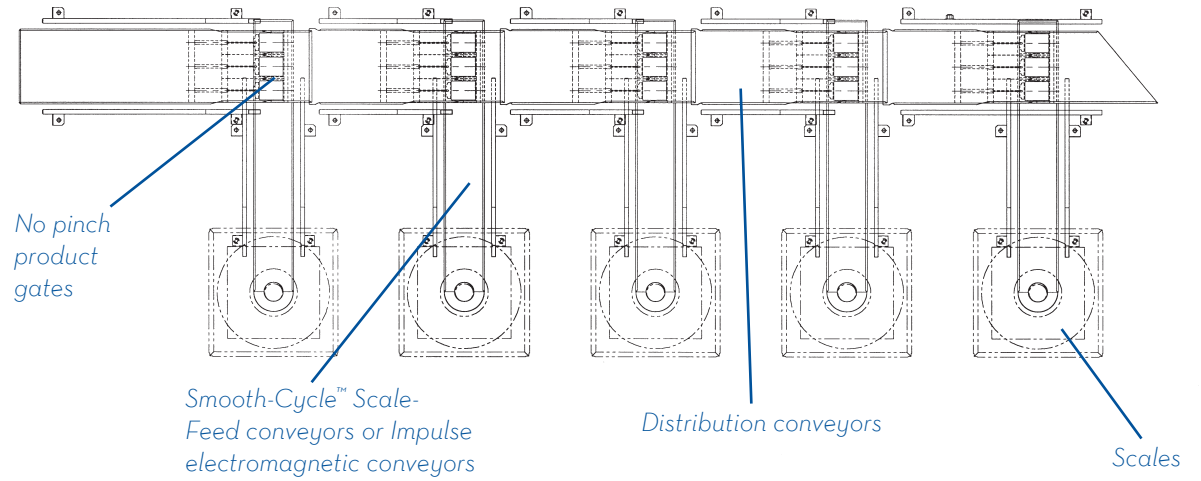

Common Product Applications

- Berries
- Bulk products
- Candy
- Cereal
- Confectionery
- Fresh-cut
- Fruit
- Legumes
- Vegetables
- Nuts
- Pet food
- Pharmaceuticals/Nutra
- Recyclables
- Root crops
- Snacks

Other applications may be used on this equipment. Call Key to find out about how your product(s) may benefit from this technology or another system.