

Impulse™ Compact

Vibratory Conveyors



Key's [Impulse™ Compact shakers](#) provide a solution for smaller electromagnetic vibratory conveying needs. This reliable and sanitary Smart Shaker® design performs well in a wide range of processing environments, providing flexible conveying speeds and accurate feeding control. Each Impulse™ Compact shaker includes controls for integration into a system, or stand-alone operation.

- Impulse™ Compact expands Key Technology's family of proven vibratory conveyors
- Impulse™ Electromagnetic Shakers offer precise metering and improved process control
- Convenient variety of standardized widths and lengths are available
- Provides simple precision-controlled conveying with efficient electromagnetic drive
- Maximizes food safety and product quality
- No sliding or rotating parts to wear, and no belts or bearings to fail
- All units are dust and moisture resistant
- Ideal for industrial applications that have harsh operating environments
- Ready to be integrated to meet the needs of specific processing/packaging systems
- Solutions for a wide variety of applications

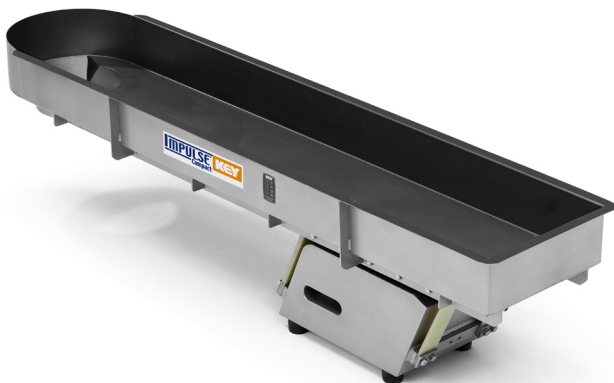

Flexibility

Every Impulse™ comes with dedicated solid-state controls that allow conveying pan amplitudes to range from 0 to 100 percent, to adjust speeds for different products and processing conditions. Impulse™ is also dust and moisture resistant, and controls are housed in NEMA4 rated enclosures, for trouble-free operation in many environments. And Impulse™ shaker drives are oil-free, which adds to their flexibility in sanitary installations. Impulse™ shakers can be integrated with existing processing and packaging lines, as well as with Key's entire line of vibratory conveying systems. Amplitude can be controlled manually by potentiometer or by external signal (0-10V) 4-20mA. And a wide range of system engineering, process control and applications testing services are available for specific processing needs.

Solutions That Make Sense

Key® knows that, at the end of the day, you measure your conveyor system's value by your bottom-line results. The Impulse™ electromagnetic shaker increases your profitability through precise process control and low maintenance. Operate on Impulse™ - can you afford not to?

Key Technology

150 Avery Street • Walla Walla, WA 99362 • USA

Phone: 509.529.2161 • Fax: 509.527.1331 • product.info@key.net • www.key.net



Impulse™ Compact Electromagnetic Vibratory Conveyors

Standard Configurations—Fast Shipment and Low Cost

- All stainless steel construction
- USDA meat, poultry, dairy finish
- 11" StrongArm™ spring arms
- 110 Volt controller

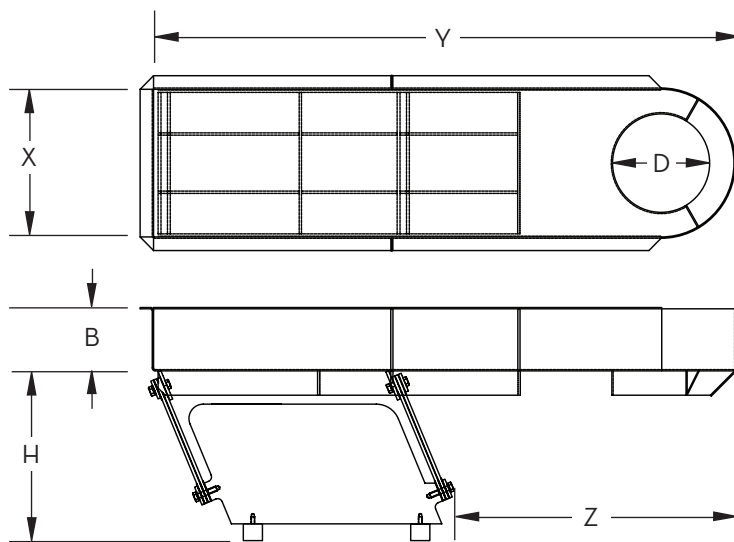

Conical Discharge

Bed Height H	Bed Depth B	Bed Width X	Bed Length Y	Bed Overhang Z	Discharge Diameter D	Smooth SS Part #	Rigid SS Part #
14"	5"	12"	66"	41"	8"	434053	434054
14"	5"	12"	78"	48"	8"	434055	434056
14"	5"	18"	69"	44"	12"	434057	434058
14"	5"	18"	81"	52"	12"	434059	434060
17"	6"	24"	72"	37"	16"	434067	434068
17"	6"	24"	84"	49"	16"	434069	434070

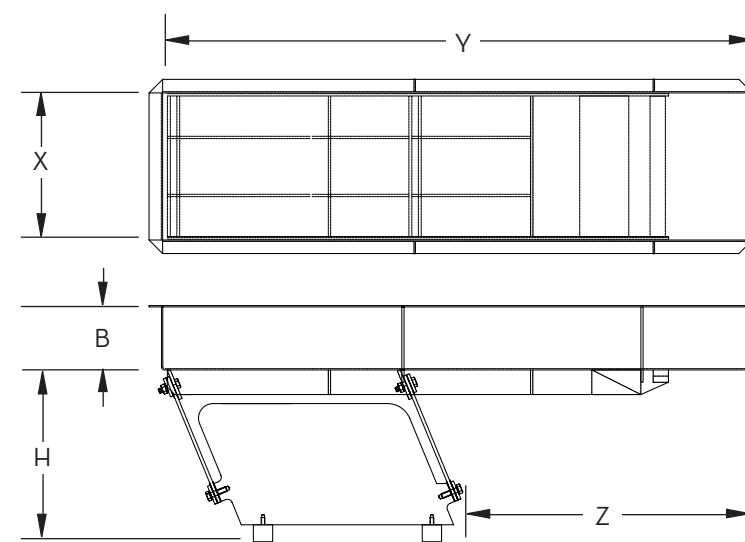

Straight Discharge

Bed Height H	Bed Depth B	Bed Width X	Bed Length Y	Bed Overhang Z	Smooth SS Part #	Rigid SS Part #
14"	5"	12"	48"	23"	434043	434044
14"	5"	12"	60"	35"	434045	434046
14"	5"	12"	72"	43"	434047	434048
14"	5"	18"	60"	35"	434049	434050
14"	5"	18"	72"	43"	434051	434052
17"	6"	24"	60"	25"	434061	434062
17"	6"	24"	72"	37"	434063	434064
17"	6"	24"	84"	43"	434065	434066

A wide range of custom sizes, configurations and surface finishes are also available to fit your line needs.