

# Scalping Vibratory Conveyor

The processing line frequently requires an efficient way to remove large particles from the main product flow. Key knows how to define the needs and work with the processors to provide the most cost-efficient method of removing these particles. Key's [Smart Shaker® Scalping Conveyor](#) provides reliable and consistent scalping performance in a flexible configuration. If you convey product by water to the shaker, we can design a system to dewater and scalp in a single operation.

## Specific Features

- Scalping top decks remove oversize product from line flow
- Standard and custom screens to match product and application requirements
- Vector-Lock™ screen clamp system to keep screen/bed inserts in place and make changeovers simple and fast
- Special collection pans or hoppers may be located beneath screen area
- Special discharge configurations to meet scalping requirements
- Applications engineers and test facilities to assist with solutions
- Available with [mechanical \(Iso-Flo®\)](#) or [electromagnetic \(Impulse™\)](#) drives

## Common Product Applications

- Berries
- Cereal
- Corn—cut
- Fruits—fresh, processed
- Green beans
- Legumes
- Nuts
- Pet food
- Recyclables
- Root crops—fresh, processed
- Snacks
- Vegetables—fresh, processed
- And Yours!

*Call Key to find out about how your products may benefit from this technology or another system.*



**Key Technology**

150 Avery Street • Walla Walla, WA 99362 • USA

Phone: 509.529.2161 • Fax: 509.527.1331 • [product.info@key.net](mailto:product.info@key.net) • [www.key.net](http://www.key.net)



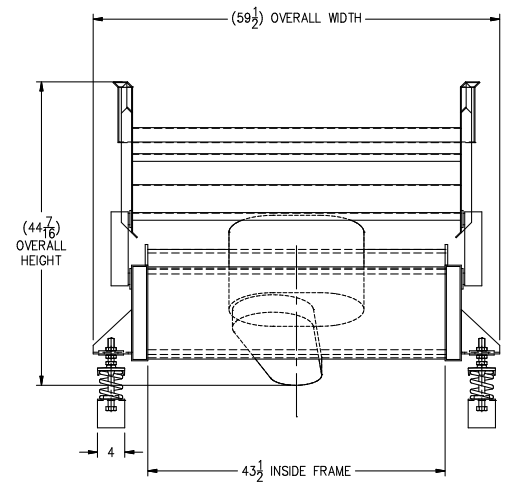
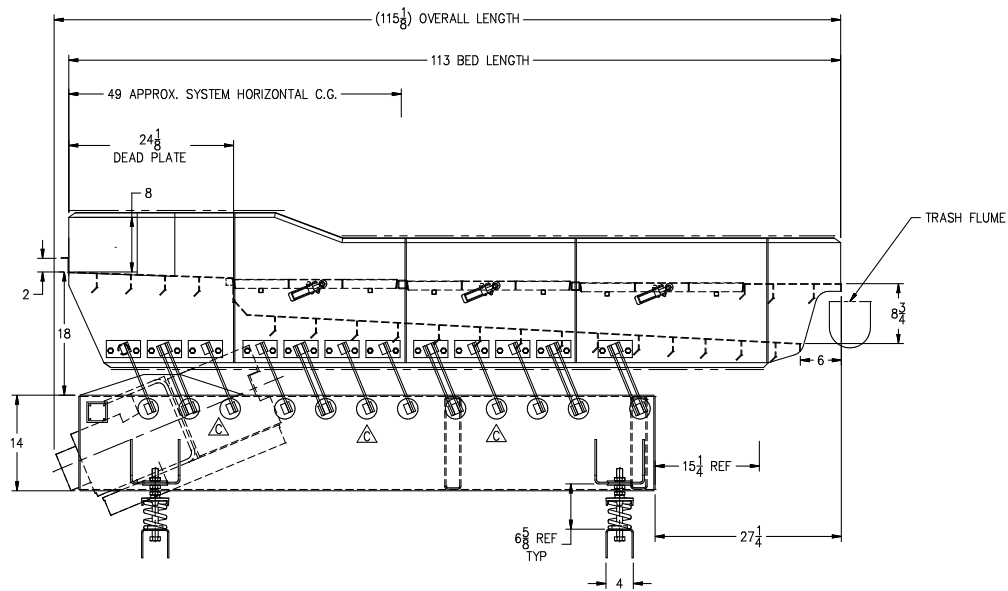
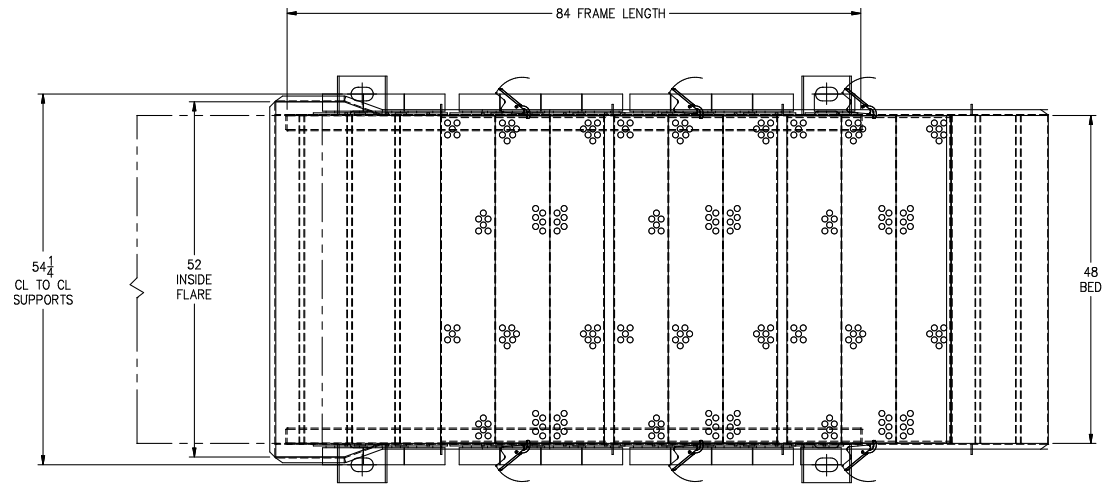

Width range: 305 mm to 1219 mm (12" to 48")  
 Length range: 1524 mm to 9144 mm (60" to 360")